

HELIX GRINDER HX-2

ECONOMICAL PRECISION THREAD GRINDER
STANDARD AUTO-LOADING SYSTEM

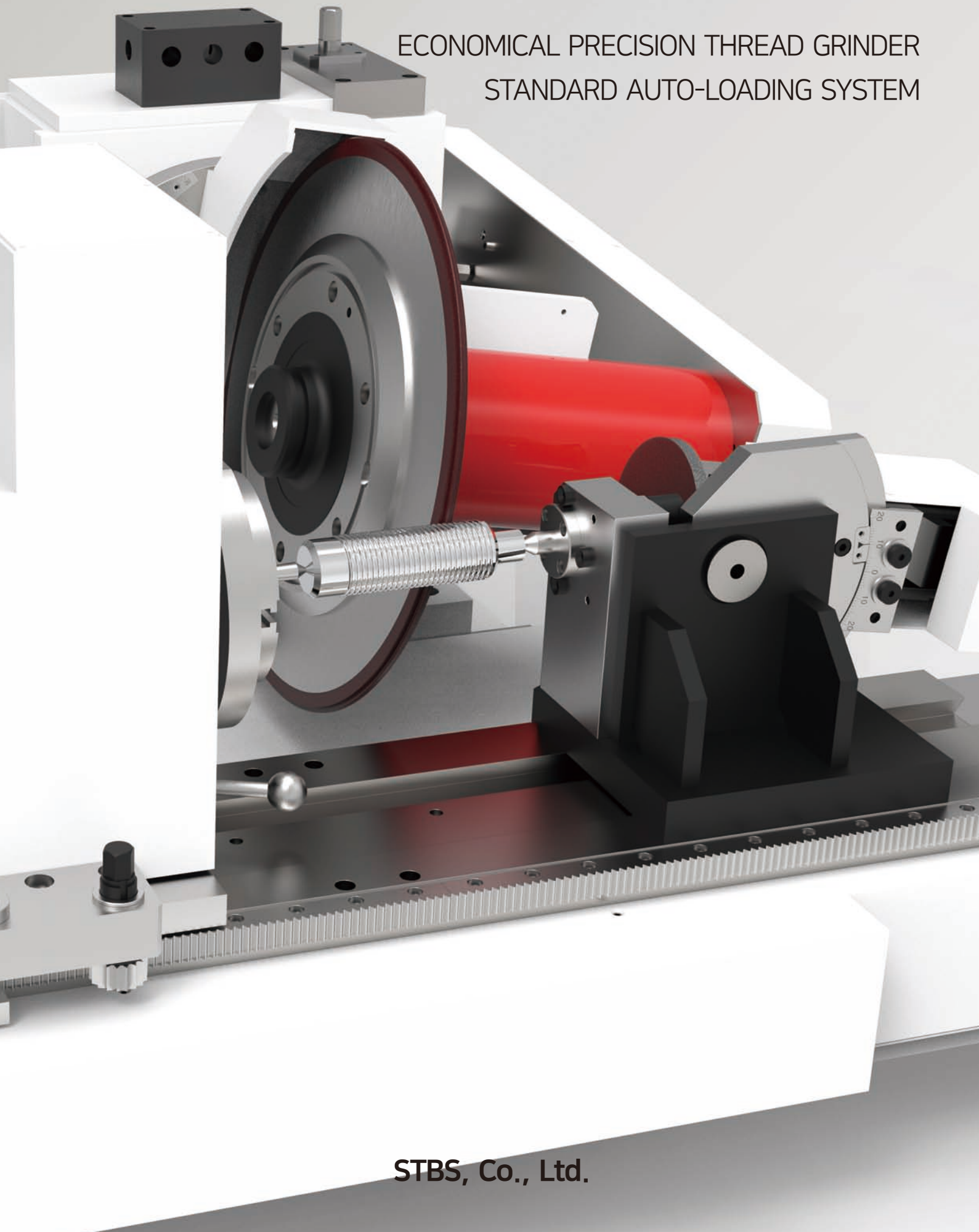

STBS, Co., Ltd.

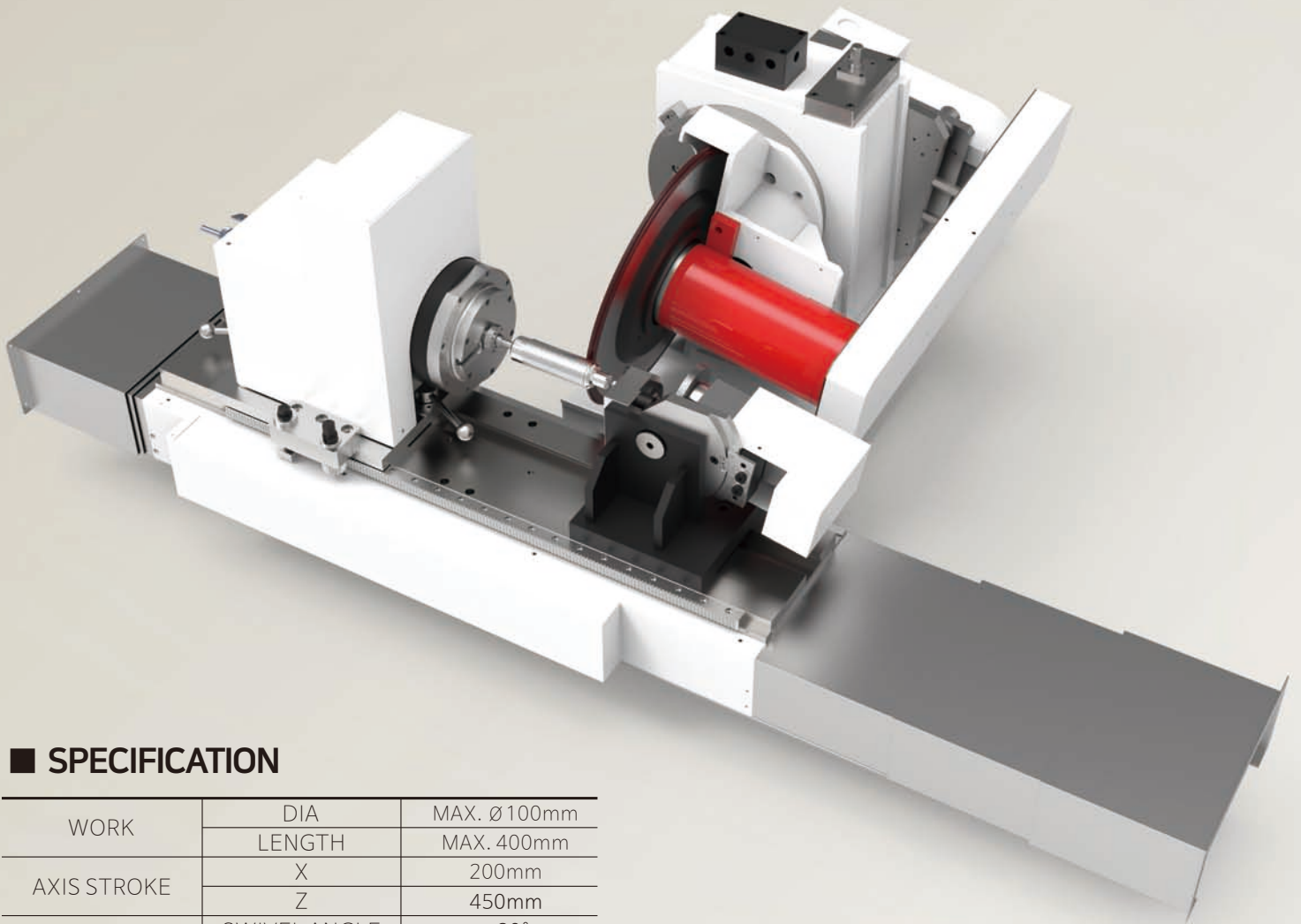

■ SPECIFICATION

WORK	DIA	MAX. \varnothing 100mm
	LENGTH	MAX. 400mm
AXIS STROKE	X	200mm
	Z	450mm
SPINDLE	SWIVEL ANGLE	$\pm 20^\circ$
	WHEEL DIA.	\varnothing 450
	NOSE	1/10 \varnothing 50
WORK HEAD	SPEED	360 rpm
	NOSE	MT4
TAIL STOCK	STROKE	30
	NOSE	MT4
DRESSING HEAD	WHEEL DIA.	\varnothing 125
	SWIVEL ANGLE	$\pm 20^\circ$
	NOSE	\varnothing 25
MOTOR	SPINDLE	5.5KW
	X	1.2KW
	Z	1.2KW
	C	1.2KW
	DRESSING	0.5KW
CNC	-	FANUC
LINEAR SCAL	-	HEIDENHAIN
AUTO LOADER STANDARD	Q'TY	30
	SIZE	MAX \varnothing 25X200mm
INSTALLATION	FLOOR	2500X2000mm
	WEIGHT	APP. 3500KG

■ WORKING AREA

